

Dimensional Data

Colombo Point-to-Point System

Blower Pack Unit V/P

Part# 90cfm-12365 124cfm-12453

Electrical: 20 amp Circuit
 11.0 amp Peak/Start-up
 9.0 amp Running current

Weight: 40 lbs.

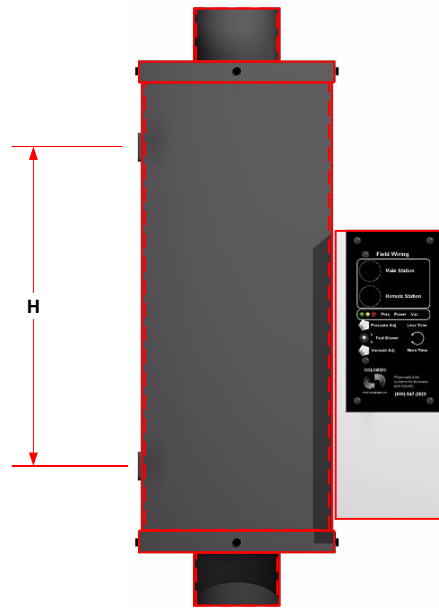
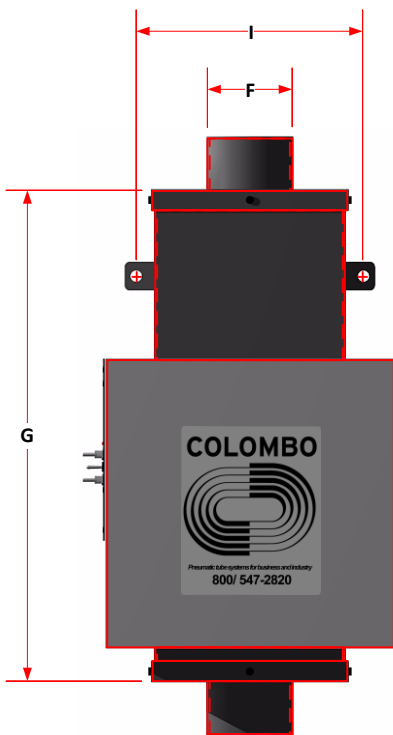
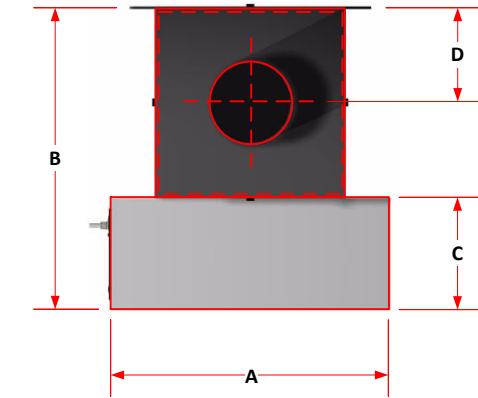

A	B	C	D	E	F	G	H	I
8.00	10.98	4.00	3.42	6.83	3.00	17.30	11.00	7.83

Rev - 3.0
 05-13-14



DISCLOSURE STATEMENT

This drawing and design are property of COLOMBO Sales & Engineering, Inc. and may not be disclosed to third parties without the expressed written permission of COLOMBO Sales & Engineering, Inc.

Colombo Sales and Engineering, Inc.

10421 Enterprise Dr. • Davisburg, MI 48350

Ph: 800.547.2820 • Fx: 248.546.7567

Dimensional Data

Colombo Point-to-Point System

Blower Pack, 248 CFM
Part# 12346

Electrical: 30 amp Circuit
24.2 amp Peak/Start-up
18.0 amp Running current

Weight: 65 lbs.

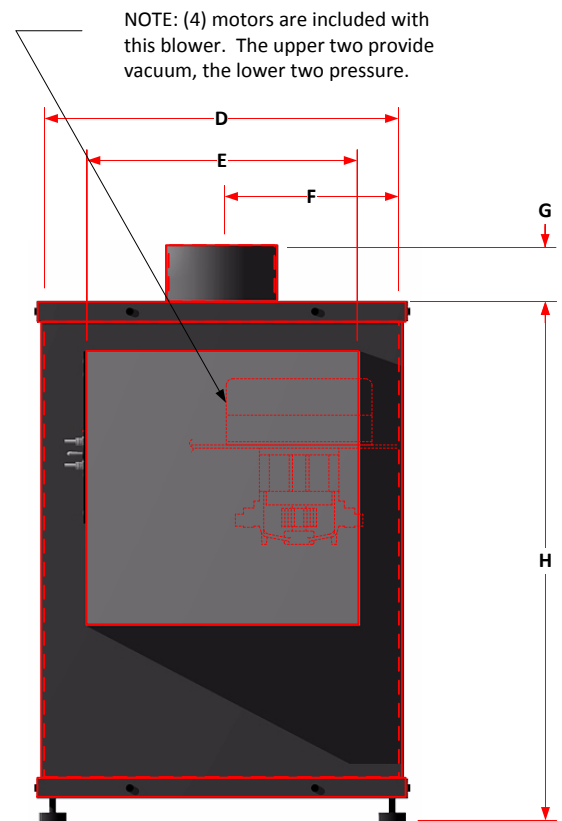
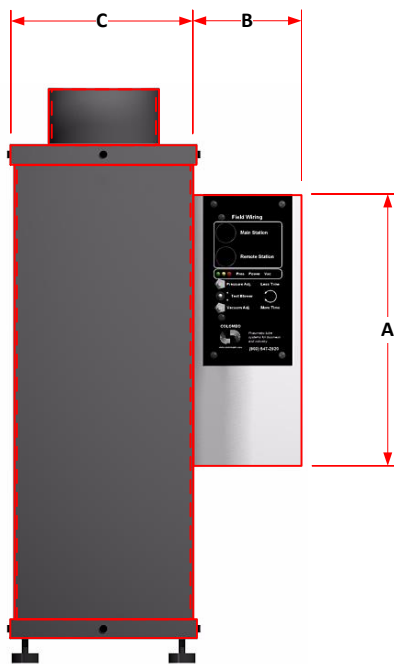
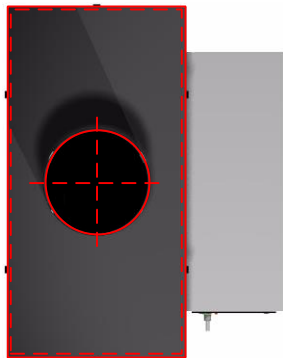

NOTE: (4) motors are included with this blower. The upper two provide vacuum, the lower two pressure.

A	B	C	D	E	F	G	H
10.00	4.00	6.88	13.50	10.00	6.75	1.50	18.25

Rev 1.0
08-02-08



DISCLOSURE STATEMENT

This drawing and design are property of COLOMBO Sales & Engineering, Inc. and may not be disclosed to third parties without the expressed written permission of COLOMBO Sales & Engineering, Inc.

Colombo Sales and Engineering, Inc.

10421 Enterprise Dr. • Davisburg, MI 48350

Ph: 800.547.2820 • Fx: 248.546.7567

Dimensional Data

Colombo Point-to-Point System

Blower Pack, 248 CFM w/ Air Shifter
 Part# 12328

power requirements: 120 VAC
 30A max
 operating temperature: 25°C

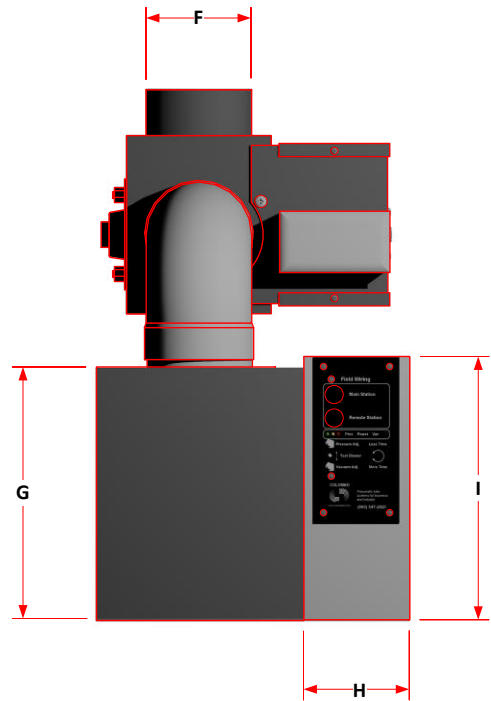
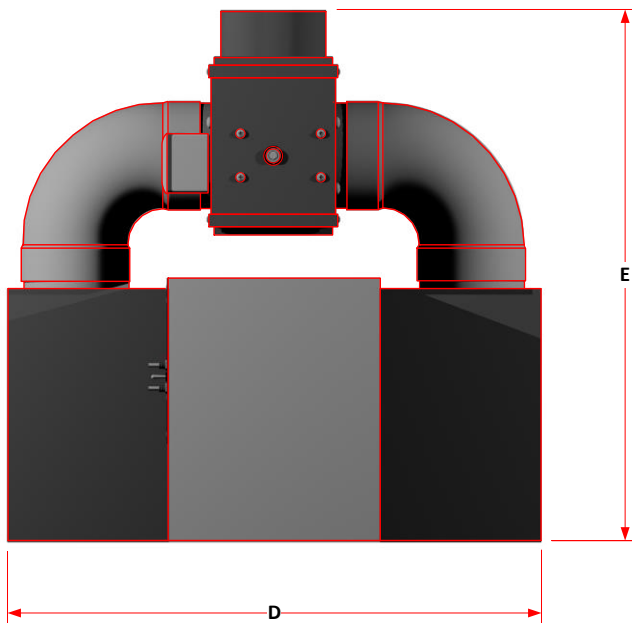
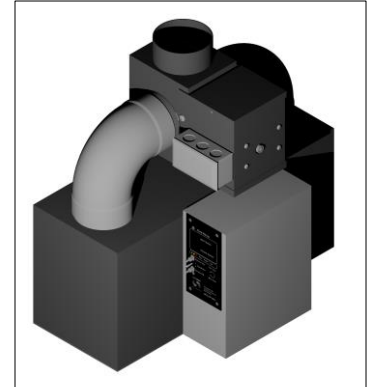
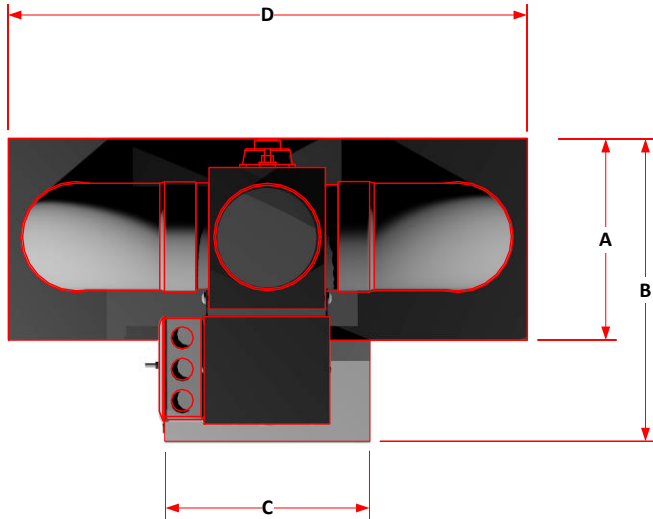

A	B	C	D	E	F	G	H	I
6.63	14.44	8.00	20.25	19.75	4.00	9.50	4.00	10.00

Rev 2.0
 03-06-09



DISCLOSURE STATEMENT

This drawing and design are property of COLOMBO Sales & Engineering, Inc. and may not be disclosed to third parties without the expressed written permission of COLOMBO Sales & Engineering, Inc.

Colombo Sales and Engineering, Inc.

10421 Enterprise Dr. • Davisburg, MI 48350

Ph: 800.547.2820 • Fx: 248.546.7567

Dimensional Data

Colombo Point-to-Point System

Blower, APU 372 CFM A/S
 Part# 12910 w/o power supply
 Part# 12974 w power supply

power requirements:
 120 VAC
 40A max

operating temperature:
 25° C

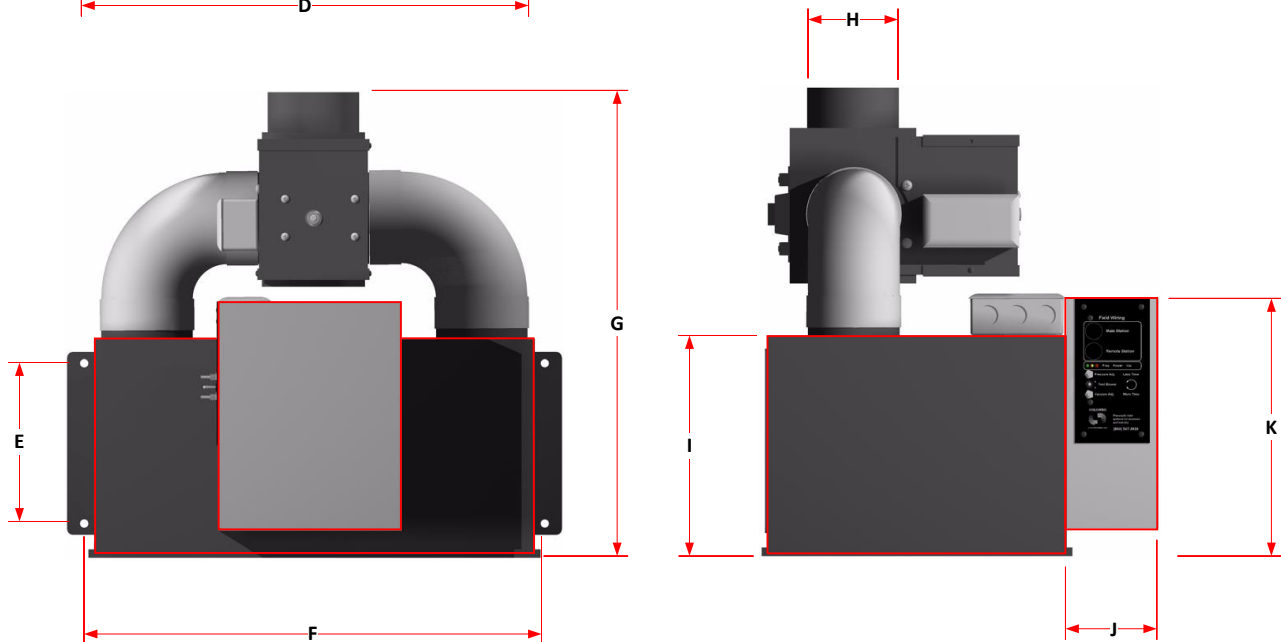
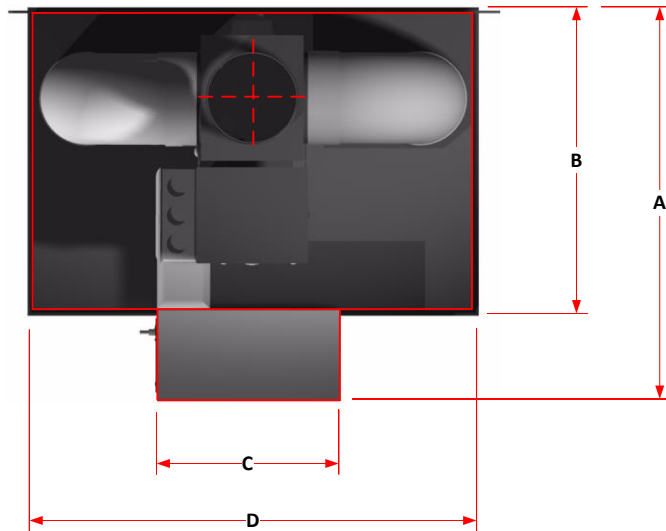
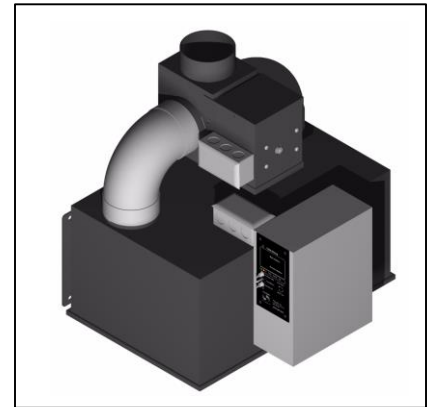

weight	78 lbs.
--------	---------

A	B	C	D	E	F	G	H	I	J	K
17.50	14.44	8.00	19.00	6.50	20.25	19.75	4.00	9.5	4.00	11.25

Rev 3.0
 11-01-10



DISCLOSURE STATEMENT

This drawing and design are property of COLOMBO Sales & Engineering, Inc. and may not be disclosed to third parties without the expressed written permission of COLOMBO Sales & Engineering, Inc.

Colombo Sales and Engineering, Inc.

10421 Enterprise Dr. • Davisburg, MI 48350

Ph: 800.547.2820 • Fx: 248.546.7567